

Firehouse Alarm and Emergency Signaling Device - Specifications

Marina Power and Lighting Equipment



Firehouse



Dimensions

Height: 44.00" (1117.60 mm)
Width: 9.500" (241.30 mm)
Depth: 9.875" (250.83 mm)

Approximate
Weight: 20-26 lbs. (9.1-11.8 kg)

UL FILE # S24715

Firehouse Base Diagram

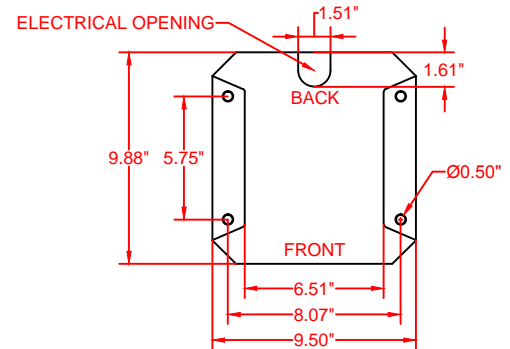

Eaton Corp. - Marina Power and Lighting, Inc. General Specifications for Firehouse Alarm & Emergency Signaling Device

All Power Pedestals Must Meet the Following:

Part I. General:

1.1 General Requirements:

- Shall be tested and certified to be in compliance with with UL2017 entitled "alarm and emergency signaling equipment."
- If a laboratory other than U.L. is used that laboratory must certify, in writing, that the alarm and emergency signaling equipment has been tested and meets all of the requirements of ANSI/UL 2017.
- Shall be certified to meet all sections of NFPA 303 DTD "2011 Marinas and Boatyards."
- Shall have the capability to house either a 10 lb. or 20 lb. A, B, and C fire extinguisher.
- Shall have downward, indirect illumination indicating the device is functioning properly.

Part II. Products:

2.1 Acceptable Manufacturers - Type SM (Self Monitoring) Emergency Signaling Device:

- Eaton - Marina Power and Energy
149 Warwick Court, Williamsburg, VA 23185.
Toll Free: 1-800-723-8009

2.2 Type SM (Self Monitoring) Emergency Signaling Device - General Specification

- Main Housing:
 - The housing shall be constructed of 20 gauge, 316L low carbon stainless steel and shall be coated with UV-resistant polyester resin over a powder coating. It shall be UL listed as a type 3R weatherproof enclosure.
 - The housing shall have the capacity to house a 10 lb. or 20 lb. A, B, and C fire extinguisher.

Firehouse Alarm and Emergency Signaling Device - Specifications

Marina Power and Lighting Equipment

- B. Access Door:
 - a. The access door shall be hinged with a stainless steel latch.
 - b. The door shall have a clear access window made of engineered resin.
 - c. Access to the fire extinguisher shall not require breakage of any part of the unit.

- C. Lighting Assembly / Housing:
 - a. The lighting top housing shall be constructed of 1/8" thick injection molded heavy resin material and shall be coated with a water based acrylic polymer. It shall be UL listed as a type 3R weatherproof enclosure.
 - b. STANDARD - Each pedestal shall be equipped with a non-metered light. The lighting assembly shall include one LED compact fluorescent light, that is protected by a 0.5 amp, in-line fuse.
 - c. OPTION - Each pedestal shall be equipped with a non-metered LED light, that is protected by a 0.5 amp, in-line fuse. 14-watt light shall be manufactured by Eaton - Marina Power & Lighting.

- D. Wiring:
 - a. The alarm and emergency signaling device shall be completely pre-wired at the factory to the load side of the terminal strip.
 - b. All load copper wiring shall be of high stranding and tin plated to resist corrosion.
 - c. The maximum size of the line wiring shall be #6 AWG.

- E. Alarm System - Visual High-Intensity Strobe:
 - a. The audible alarm system shall have an output of 68 dBA, and a strobe light shall simultaneously activate to indicate the removal of the life ring and / or fire extinguisher.

- F. Grounding:
 - a. All exposed metallic parts must have an integral ground that is a part of the equipment grounding system.

- G. Fire Extinguisher (Optional):
 - a. Each cabinet shall be equipped with a 10 lb. or 20 lb. ABC fire extinguisher.

- H. Life Ring (Optional):
 - a. Each cabinet shall be equipped with a 30" life ring and provisions to sound an alarm system when the life ring is removed.

(END OF SECTION)

Firehouse Alarm and Emergency Signaling Device - Specifications

Marina Power and Lighting Equipment

Product Features

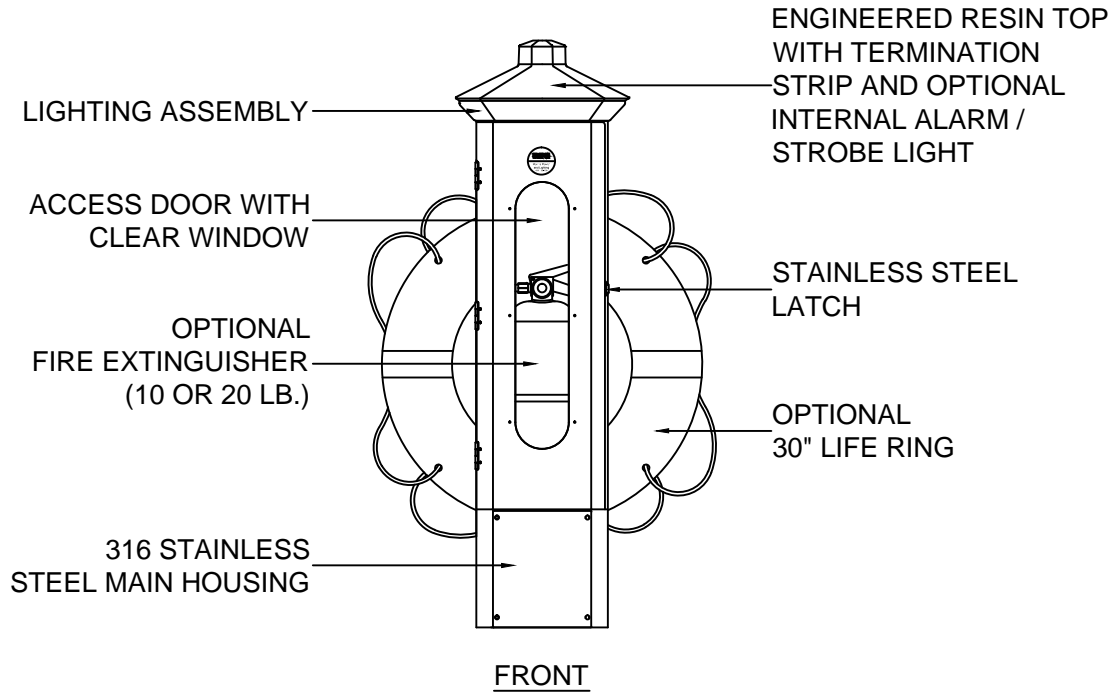

Dimensions

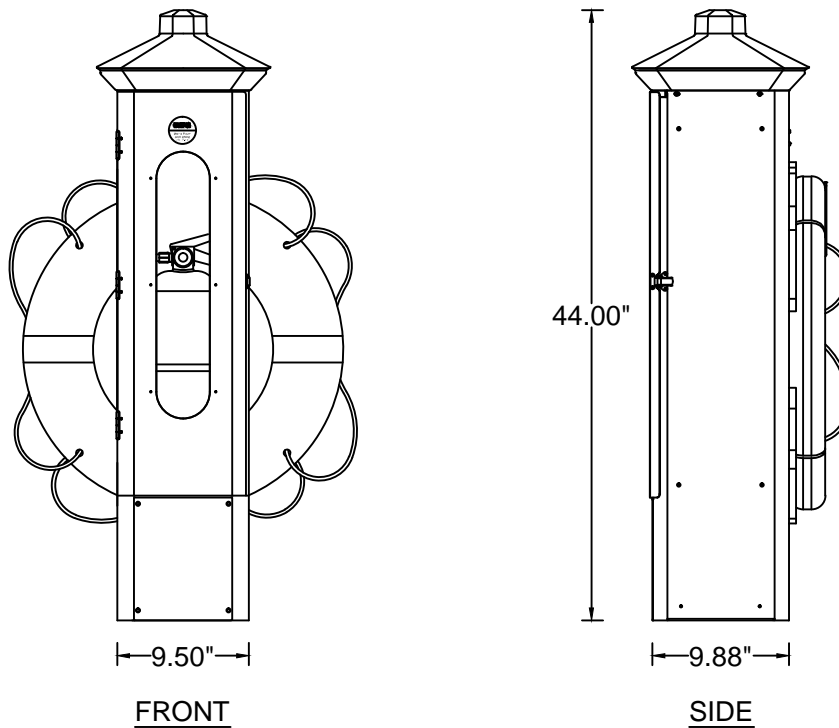

Firehouse Alarm and Emergency Signaling Device - Specifications

Marina Power and Lighting Equipment

Base Dimensions

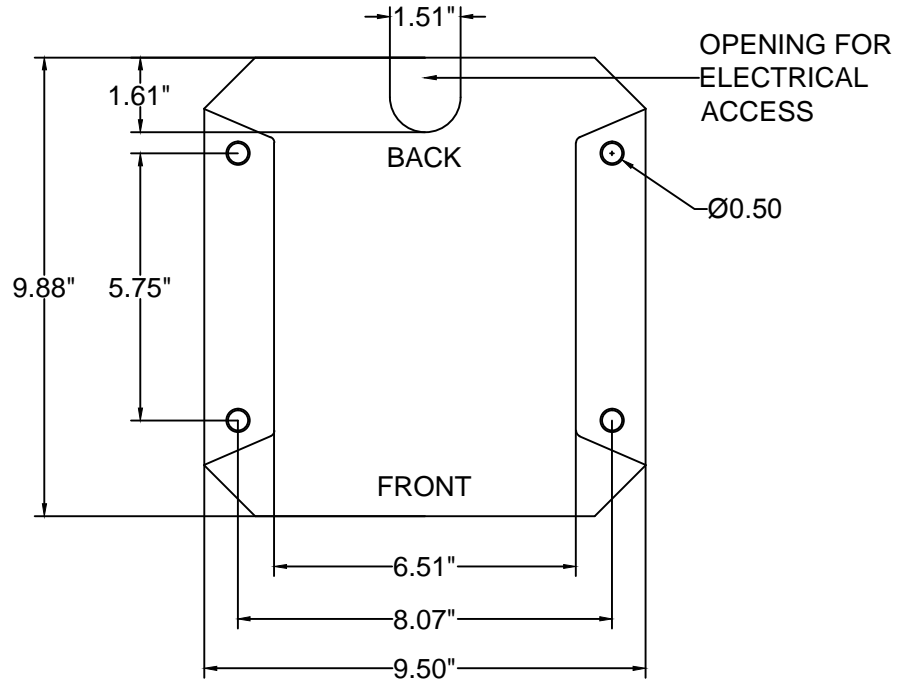

Wiring Diagram - Terminal Block

Wire Colors Per NEC

Line 1	L1	Black
Neutral	N	White
Ground	G	Green

